

# 工程數學特論

## Selected Topics in Engineering Mathematics

授課者：丁建均，王新博

教學網頁：<https://djj.ee.ntu.edu.tw/EM.htm>  
(請上課前來這個網站將講義印好)

歡迎大家來修課！

## 授課者：丁建均，王新博

### 丁建均

Office：明達館723室，TEL：33669652

Office hour：週一下午，週三上午，週四下午，週五下午皆可以來找我

個人網頁：<https://disp.ee.ntu.edu.tw/>

E-mail: [jjding@ntu.edu.tw](mailto:jjding@ntu.edu.tw)

### 王新博

Office：電二237、博理508

Discord：<https://discord.gg/yWPjB2tRTt>

Office hour：一下午、三四五整天

個人網頁：<https://hsin-po.wang>

E-mail: [hsinpo@ntu.edu.tw](mailto:hsinpo@ntu.edu.tw)

上課時間：星期二第 7, 8, 9 節 (PM 14:20~17:20)

## 上課方式

(1) 錄影，影片將藉由 NTU Cool 下載 <http://cool.ntu.edu.tw>

(2) 現場 (明達館205室)

教材：講義

評分方式：五次作業 65%，期末考 35%

用 NTU Cool 來繳交作業的電子檔 <http://cool.ntu.edu.tw>

(紙本用 PDF files 繳交，並且附程式碼)

考試：Open book，限時210分鐘

參考教材：

- [1] D. G. Zill and Michael R. Cullen, Differential Equations-with Boundary-Value Problem (metric version), 9th edition, Cengage Learning, 2017.
- [2] D. G. Zill, W. S. Wright, and J. J. Ding, Engineering Mathematics, Metric Edition, Cengage Learning, Taipei, Taiwan, 2019.
- [3] R. N. Bracewell, The Fourier Transform and Its Applications, 3<sup>rd</sup> ed., McGraw Hill, Boston, 2000.
- [4] R. D. Yates and D. J. Goodman, Probability and Stochastic Processes, 3<sup>rd</sup> Edition, John Wiley and Sons, 2015.
- [5] A. Papoulis and S.U. Pillai, Probability, Random Variables, and Stochastic Processes, 4th edition, Mcgraw-Hill, 2002.
- [6] R. A. Horn and C. R. Johnson, Matrix Analysis, 2nd ed., New York: Cambridge University Press, 2013.
- [7] G. H. Golub and C. F. Van Loan, Matrix Computations, 4th ed., Baltimore: The Johns Hopkins University Press, 2013.

## 上課日期

5

Week Number	Date (Tuesday)	Remark
1.	2/24	3n 週出作業 3n+2 週交作業
2.	3/3	
3.	3/10	出 HW1
4.	3/17	
5.	3/24	交 HW1
6.	3/31	出 HW2
7.	4/7	
8.	4/14	交 HW2
9.	4/21	出 HW3
10.	4/28	
11.	5/5	交 HW3
12.	5/12	出 HW4
13.	5/19	
14.	5/26	交 HW4
15.	6/2	出 HW5
	6/9	期末考
	6/16	交 HW5

## 注意事項：

- (1) 請上課前，來這個網頁，將上課資料印好。  
<https://djj.ee.ntu.edu.tw/EM.htm>
- (2) 請各位同學踴躍出席。
- (3) 作業一次10題，作業不可以抄襲。作業若寫錯但有用心寫仍可以有40%~90%的分數，但抄襲或借人抄襲不給分。
- (4) 作業較難的題目都會給予充分的提示，但一定要自己寫
- (5) 期末考採行 open book 的方式，考試時間為 210分鐘  
出題範圍為講義有提到的部分(除非特別註明只教不考)

## 注意事項：

- (6) 只教不考的範圍是期末考不會考，但有可能作業會由當中出題
- (7) 每三週一次作業，每次作業會有一個以上程式題
- (8) 在解答公佈前作業皆可補交，但遲交將扣 15% 的分數  
各次作業解答公佈時間為，  
HW1: 4/21, HW2: 5/5, HW3: 5/19, HW4: 6/2, HW5: 6/20
- (9) 不需記任何一個式子，不需磨練運算速度，但是要了解物理意義，培養實際上解決問題的能力

## Matlab Program

Download: 請洽台大各系所

### 參考書目

洪維恩，Matlab 程式設計，旗標，台北市，2013. (合適的入門書)

張智星，Matlab 程式設計入門篇，第四版，碁峰，2016.

預計看書學習所花時間：3~5 天

## Python Program

Download: <https://www.python.org/>

### 參考書目

葉難，Python 程式設計入門，博碩，2015

黃健庭，Python 程式設計：從入門到進階應用，全華，2020

The Python Tutorial      <https://docs.python.org/3/tutorial/index.html>

- (A) Differential Equation Part
  - (1) Numerical Methods and Nonlinear DEs (2W)
  - (2) Partial Differential Equations (3W)
  - (3) Function Approximation (1W)
- (B) Fourier Analysis Part
  - (1) Fourier Analysis (1.5W)
  - (2) 2D FT and Discrete FT (0.5W)
- (C) Linear Algebra Part
  - (1) LU, PJP, QR, SVD (1.5W)
  - (2) Vector Approximation & Compressed Sensing (1.5W)
- (D) Probability and Statistics Part
  - (1) Hypothesis Testing and p-hacking (1W)
  - (2) PCA & Least Square (1W)
  - (3) Brownian Motion (1W)
- (E) Numerical Methods and Programming (1W)
  - (1) FFT
  - (2) Finite Element Method with NumPy
  - (3) Arbitrary Precision Floating-Point Numbers

## 課程定位

- (1) Advanced Parts of (i) Differential Equations, (ii) Signals and Systems, (iii) Linear Algebra, (iv) Probability and Statistics, and (v) Numerical Methods
- (2) Connection between the Undergraduate Courses and the Mathematical Tools Required for Research
- (3) Improving the Ability to Solve Practical Mathematical Problems

## 附錄一 Table of Integration

$1/x$	$\ln x  + c$
$\cos(x)$	$\sin(x) + c$
$\sin(x)$	$-\cos(x) + c$
$\tan(x)$	$-\ln \cos(x)  + c$
$\cot(x)$	$\ln \sin(x)  + c$
$a^x$	$a^x/\ln(a) + c$
$\frac{1}{x^2 + a^2}$	$\frac{1}{a} \tan^{-1} \frac{x}{a} + c$
$1/\sqrt{a^2 - x^2}$	$\sin^{-1}(x/a) + c$
$-1/\sqrt{a^2 - x^2}$	$\cos^{-1}(x/a) + c$
$x e^{ax}$	$\frac{e^{ax}}{a} \left( x - \frac{1}{a} \right) + c$
$x^2 e^{ax}$	$\frac{e^{ax}}{a} \left( x^2 - \frac{2x}{a} + \frac{2}{a^2} \right) + c$

<https://integrals.wolfram.com/index.jsp>

輸入數學式，就可以查到積分的結果

範例：

(a) 先到 [integrals.wolfram.com/index.jsp](https://integrals.wolfram.com/index.jsp) 這個網站

(b) 在右方的空格中輸入數學式，例如

數學式

Wolfram Mathematica  
ONLINE INTEGRATOR  
*The world's only full-power integration solver*

HOW TO ENTER INPUT | RANDOM EXAMPLE

$\int \cos(ax)+b \, dx$

Compute Online With Mathematica

(c) 接著按 “Compute Online with Mathematica”

就可以算出積分的結果

The screenshot displays the Wolfram Mathematica Online Integrator interface. At the top, it reads "Wolfram Mathematica ONLINE INTEGRATOR" and "The world's only full-power integration solver". Below this, there are links for "HOW TO ENTER INPUT" and "RANDOM EXAMPLE". The input field contains the expression  $\int \cos(ax)+b \, dx$ . A red arrow labeled "按" (press) points to the blue button labeled "Compute Online With Mathematica". Below the button, there are links for "Traditional Form", "Input Form", and "Output Form". The result is displayed in a large box, showing the integral  $\int b + \cos(ax) \, dx =$  followed by the expression  $bx + \frac{\sin(ax)}{a}$ . A red arrow labeled "結果" (result) points to this result box. At the bottom right, it says "Time to compute: < 0.01 second".

按

Compute Online With Mathematica

Traditional Form | Input Form | Output Form

結果

$\int b + \cos(ax) \, dx =$

$bx + \frac{\sin(ax)}{a}$

Time to compute: < 0.01 second

(d) 有時，對於一些較複雜的數學式，下方還有連結，點進去就可以看到相關的解說<sup>14</sup>

**Wolfram Mathematica**  
ONLINE INTEGRATOR  
*The world's only full-power integration solver*

HOW TO ENTER INPUT | RANDOM EXAMPLE

$\int \text{exp}(-a*x^2) dx$

Compute Online With Mathematica

Traditional Form | Input Form | Output Form

$$\int e^{-ax^2} dx = \frac{\sqrt{\pi} \operatorname{erf}(\sqrt{a} x)}{2\sqrt{a}}$$

Time to compute: < 0.01 second

[erf\(x\); Erf\[x\]; error function \[properties\]](#)

 連結

其他有用的網站

<http://mathworld.wolfram.com/>

對微分方程的定理和名詞作介紹的百科網站

<http://www.sosmath.com/tables/tables.html>

眾多數學式的 mathematical table (不限於微分方程)

<http://www.seminaire-sherbrooke.qc.ca/math/Pierre/Tables.pdf>

眾多數學式的 mathematical table，包括 convolution, Fourier transform, Laplace transform, Z transform

軟體當中，[Maple](#), [Mathematica](#), [Matlab](#) 皆有微積分結果查詢有功能

# **Part A: Differential Equations**

# 1. Numerical Methods and Nonlinear Differential Equations

1.1 Review (只教不考)

1.2 Numerical Methods (只教不考)

1.3 Nonlinear Differential Equations

1.4 Applications of Nonlinear Differential Equations

[1] D. G. Zill and Michael R. Cullen, Differential Equations-with Boundary-Value Problem (metric version), 9th edition, Cengage Learning, 2017.

[2] <http://djj.ee.ntu.edu.tw/DE.htm>

## 1.1 Review

### 1.1.1 Definitions

(1) **Differential Equation (DE):** any equation containing derivation

$$\frac{dy(x)}{dx} = 1 \quad x: \text{ independent variable 自變數}$$

$y(x): \text{ dependent variable 應變數}$

$$y = \int 1 dx + C = x + C$$

$$\frac{d^5 f(x)}{dx^5} + 2 \frac{d^3 f(x)}{dx^3} = \cos(x)$$

(2) Ordinary Differential Equation (ODE): 常微分

differentiation with respect to one independent variable

$$\frac{d^3 u}{dx^3} + \frac{d^2 u}{dx^2} + \frac{du}{dx} + \cos(6x)u = 0 \quad \frac{dx}{dt} + \frac{dy}{dt} + \frac{dz}{dt} = 2xy + z$$

(3) Partial Differential Equation (PDE): 偏微分

differentiation with respect to two or more independent variables

$$\frac{\partial^2 u}{\partial x^2} + \frac{\partial^2 u}{\partial y^2} = 0 \quad \frac{\partial x}{\partial t} = \frac{\partial y}{\partial \tau}$$

**(4) Order of a Differentiation Equation:** the order of the highest derivative in the equation

$$\frac{d^7 u}{dx^7} + 2 \frac{d^6 u}{dx^6} + 2 \frac{d^5 u}{dx^5} + 4 \frac{d^4 u}{dx^4} = 0 \quad 7^{\text{th}} \text{ order}$$

$$\frac{d^2 y}{dx^2} + 4 \frac{dy}{dx} - 5y = e^x \quad 2^{\text{nd}} \text{ order}$$

### **(5) Standard Form**

For a DE, if the **coefficient** of the **highest** derivative term is 1, then the DE is called the **standard form** DE.

### (6) Linear Differentiation Equation:

$$a_n(x) \frac{d^n y}{dx^n} + a_{n-1}(x) \frac{d^{n-1} y}{dx^{n-1}} + \cdots + a_1(x) \frac{dy}{dx} + a_0(x) y = g(x)$$

All of the coefficient terms  $a_m(x)$   $m = 1, 2, \dots, n$  are independent of  $y$ .

### (7) Non-Linear Differentiation Equation

$$(y+3) \frac{d^2 y}{dx^2} + \frac{dy}{dx} + 2y = x$$

$$\frac{d^2 y}{dx^2} + \frac{dy}{dx} + y^2 = e^x$$

$$\frac{d^2 y}{dx^2} + \frac{dy}{dx} + e^y = e^x$$

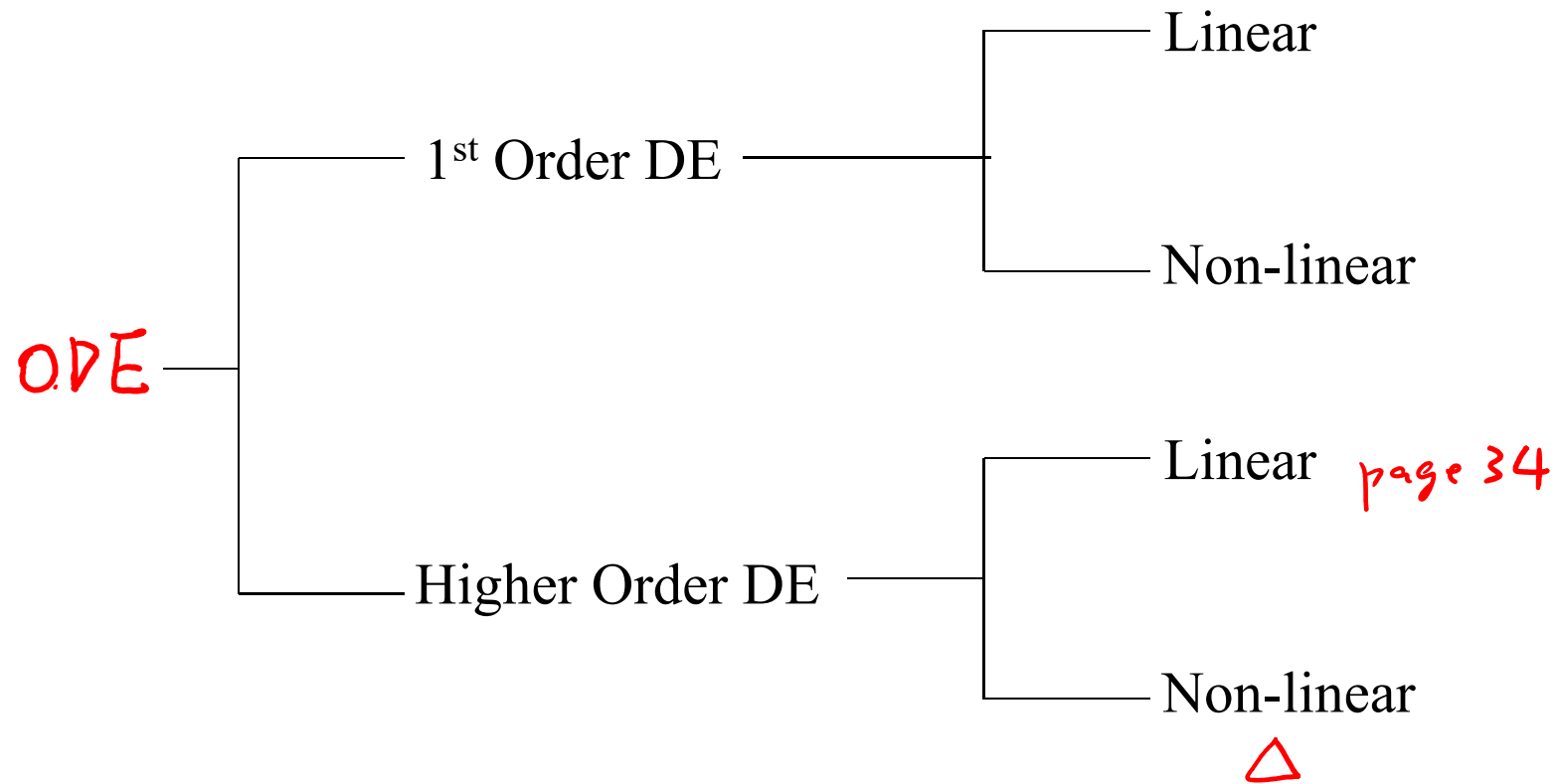

## 1.1.2 First Order DE

Methods:

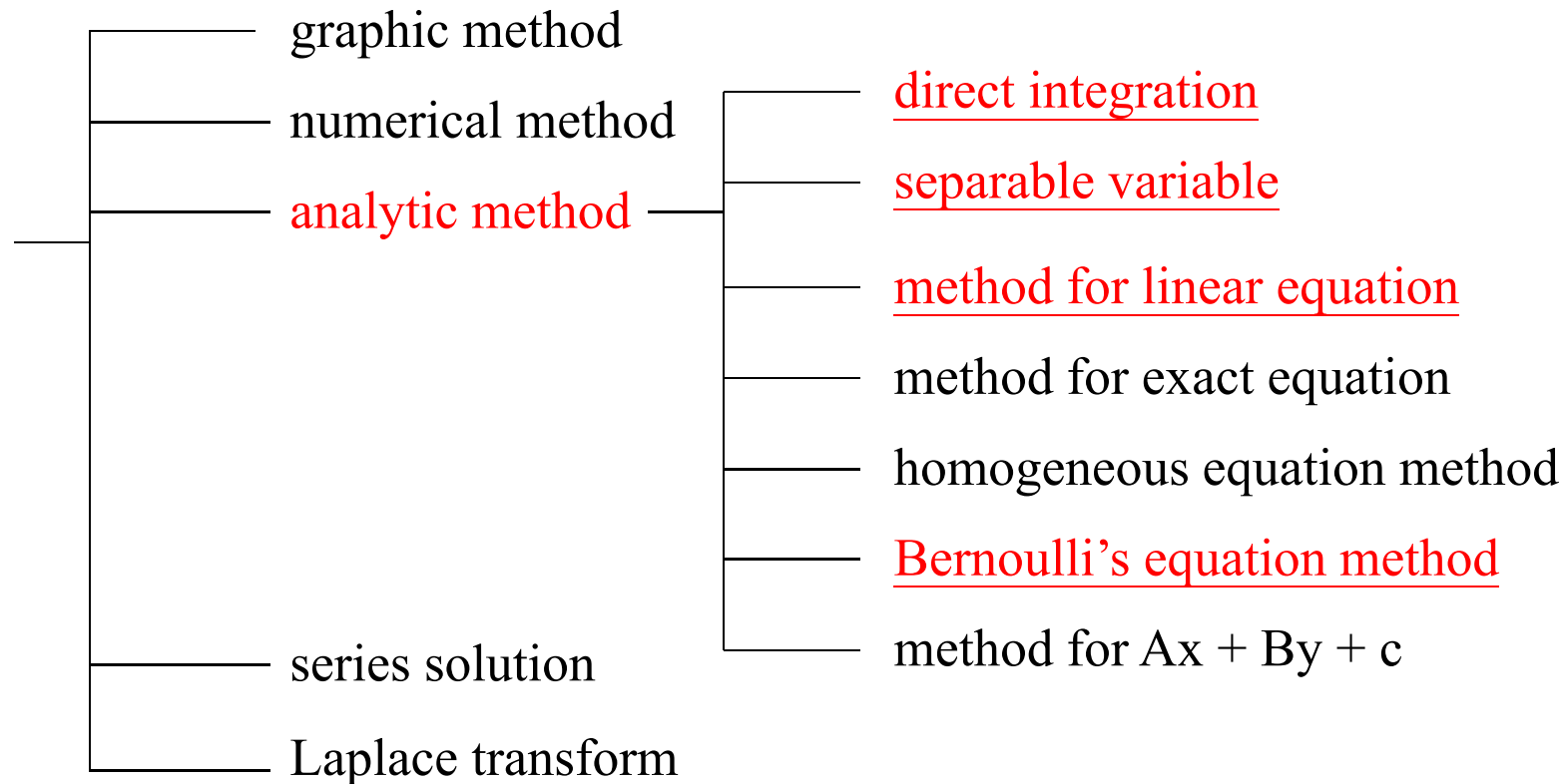

## Methods of Solving the 1<sup>st</sup> Order DE

### (1) Direct computation

條件： $\frac{dy}{dx} = f(x)$

破解法：直接積分

$$y(x) = \int f(x) dx + C$$

### (2) Separable variable

條件： $\frac{dy}{dx} = g(x)h(y)$

破解法：x, y 各歸一邊後積分

### (3) Linear DE

條件：linear DE

$$\frac{dy}{dx} + P(x)y = f(x)$$

破解法：算  $e^{\int P(x) dx}$

*integrating factor*

$$y = e^{-\int P(x) dx} \int e^{\int P(x) dx} f(x) dx + ce^{-\int P(x) dx}$$

或

$$\frac{d}{dx} \left[ e^{\int P(x) dx} y \right] = e^{\int P(x) dx} f(x)$$

$$a_1(x) \frac{dy}{dx} + a_0(x)y = g(x)$$

$$\frac{dy}{dx} + \frac{a_0(x)}{a_1(x)} y = \frac{g(x)}{a_1(x)}$$

$$P(x) = a_0(x) / a_1(x)$$

## (4) Exact equation

$$\text{條件} : \frac{dy}{dx} = -\frac{M(x, y)}{N(x, y)}$$

$$\frac{\partial M(x, y)}{\partial y} = \frac{\partial N(x, y)}{\partial x}$$

## (4-1) Exact equation 變型

$$\text{條件} : \frac{dy}{dx} = -\frac{M(x, y)}{N(x, y)}$$

$(M_y - N_x) / M$  independent of  $x$

## (4-2) Exact equation 變型

$$\text{條件} : \frac{dy}{dx} = -\frac{M(x, y)}{N(x, y)}$$

$(M_y - N_x) / N$  independent of  $y$

破解法 : double  $N$  method

$$\text{先處理} \quad \frac{\partial f}{\partial x} = M(x, y)$$

$$\text{再處理} \quad \frac{\partial f}{\partial y} = N(x, y) \quad (\text{或反過來})$$

$$\text{破解法} : \mu(y) = e^{\int \frac{(N_x - M_y)}{M} dy}$$

$$\frac{dy}{dx} = -\frac{\mu(y)M(x, y)}{\mu(y)N(x, y)} \quad \text{is exact}$$

$$\text{破解法} : \mu(x) = e^{\int \frac{(M_y - N_x)}{N} dx}$$

$$\frac{dy}{dx} = -\frac{\mu(x)M(x, y)}{\mu(x)N(x, y)} \quad \text{is exact}$$

## (5) Homogeneous equation

$$\text{條件：} \frac{dy}{dx} = -\frac{M(x, y)}{N(x, y)}$$

$$M(tx, ty) = t^\alpha M(x, y)$$

$$N(tx, ty) = t^\alpha N(x, y)$$

破解法：  $u = y/x$ , ( $y = xu$ )

$$dy = udx + xdu$$

再用 separable variable method

## (6) Bernoulli's Equation

When  $n \neq 0$ , linear

$$\text{條件：} \frac{dy}{dx} = -P(x)y + f(x)y^n$$

破解法：  $u = y^{1-n}$

$$\frac{dy}{dx} = \frac{1}{1-n} u^{\frac{n}{1-n}} \frac{du}{dx}$$

再用 linear DE 的方法

(7)  $Ax + By + C$ 

$$\text{條件：} \frac{dy}{dx} = f(Ax + By + C)$$

破解法：  $u = Ax + By + c$

$$\frac{dy}{dx} = \frac{1}{B} \frac{du}{dx} - \frac{A}{B}$$

## (2) Separable Variable Method

If  $\frac{dy}{dx} = g(x)h(y)$ , then

Step 1  $\frac{dy}{h(y)} = g(x)dx$  分離變數

$$p(y)dy = g(x)dx$$

where  $p(y) = 1/h(y)$

Step 2  $\int p(y)dy = \int g(x)dx$  個別積分

$$P(y) + c_1 = G(x) + c_2$$

where

$$\frac{dP(y)}{dy} = p(y)$$

$$\frac{dG(x)}{dx} = g(x)$$

$$P(y) = G(x) + c$$

Extra Step: Initial conditions

**[Example 1]** (Zill, Page 48)

$$\frac{dy}{dx} - \frac{y}{1+x} = 0$$

Step 1  $\frac{dy}{y} = \frac{dx}{1+x}$

Step 2  $\ln|y| = \ln|1+x| + c_1$

$$|y| = e^{\ln|1+x|} e^{c_1} \longrightarrow y = \pm e^{c_1} e^{\ln|1+x|}$$

$$y = \pm e^{c_1} |1+x| = \pm e^{c_1} (1+x) \quad c = \pm e^{c_1}$$

$$y = c(1+x)$$

### (3) Linear DE Method

(Step 1) Obtain the **standard form** and find  $P(x)$

$$\frac{dy}{dx} + P(x)y = f(x)$$

(Step 2) Calculate  $e^{\int P(x)dx}$

(Step 3) The standard form of the linear 1<sup>st</sup> order DE can be rewritten as:

$$\frac{d}{dx} \left[ e^{\int P(x)dx} y \right] = e^{\int P(x)dx} f(x)$$

(Step 4) Further solve the equation.

(Extra Step) Initial conditions

**[Example 2]** (Zill, Page 58)

$$x \frac{dy}{dx} - 4y = x^6 e^x$$

**Step 1**  $\frac{dy}{dx} - 4 \frac{y}{x} = x^5 e^x$ ,  $P(x) = -\frac{4}{x}$

**Step 2**  $e^{\int P(x) dx} = e^{-4 \ln|x|} = |x|^{-4} = x^{-4}$  for  $x > 0$

**Step 3**  $\frac{d}{dx} [x^{-4} y] = x e^x$

**Step 4**  $x^{-4} y = (x-1)e^x + c$

$$y = (x^5 - x^4)e^x + cx^4$$

## (6) Bernoulli's Equation

**【Definition】** Bernoulli's equation:

$$\frac{dy}{dx} + P(x)y = f(x)y^n$$

u  
↓

so  $y^{-n} \frac{dy}{dx} + P(x)y^{1-n} = f(x)$

We can set  $y = u^{\frac{1}{1-n}}$ ,  $\frac{dy}{dx} = \frac{1}{1-n} u^{\frac{n}{1-n}} \frac{du}{dx}$ , and the method of solving

the 1<sup>st</sup> order linear DE to solve the Bernoulli's equation.

$$\frac{dy}{dx} = \frac{dy}{du} \frac{du}{dx} = \frac{du^{\frac{1}{1-n}}}{du} \frac{du}{dx} = \frac{1}{1-n} u^{\frac{n}{1-n}} \frac{du}{dx}$$

**(Chain rule)**

$$y^{-n} \frac{dy}{dx} = u^{\frac{-n}{1-n}} \frac{1}{1-n} u^{\frac{n}{1-n}} \frac{du}{dx} = \frac{1}{1-n} \frac{du}{dx}$$

$$y^{-n} \frac{dy}{dx} + P(x)y^{1-n} = f(x)$$



$$\frac{1}{1-n} \frac{du}{dx} + P(x)u = f(x)$$

**[Example 3]** (Zill, Page 74)

$$\boxed{x \frac{dy}{dx} + y = x^2 y^2}$$

Previous Step: Conclude that it is a **Bernoulli's equation** with  $n = 2$ .

Step 1: set  $u = y^{-1}$  ( $y = u^{-1}$ )  $\frac{dy}{dx} = \frac{dy}{du} \frac{du}{dx} = -u^{-2} \frac{du}{dx}$

(Chain rule)

Step 2: Convert into the 1<sup>st</sup> order linear DE (standard form)

$$\text{原式} \longrightarrow -xu^{-2} \frac{du}{dx} + u^{-1} = x^2 u^{-2} \longrightarrow \frac{du}{dx} - \frac{1}{x} u = -x$$

Step 3: Obtain the solution of the 1<sup>st</sup> order DE

$$u = -x^2 + cx$$

Step 4: Substituted by  $u = y^{-1}$

$$\boxed{y = \frac{1}{-x^2 + cx}}$$

## 1.1.3 Linear Higher Order DE

33

Methods:

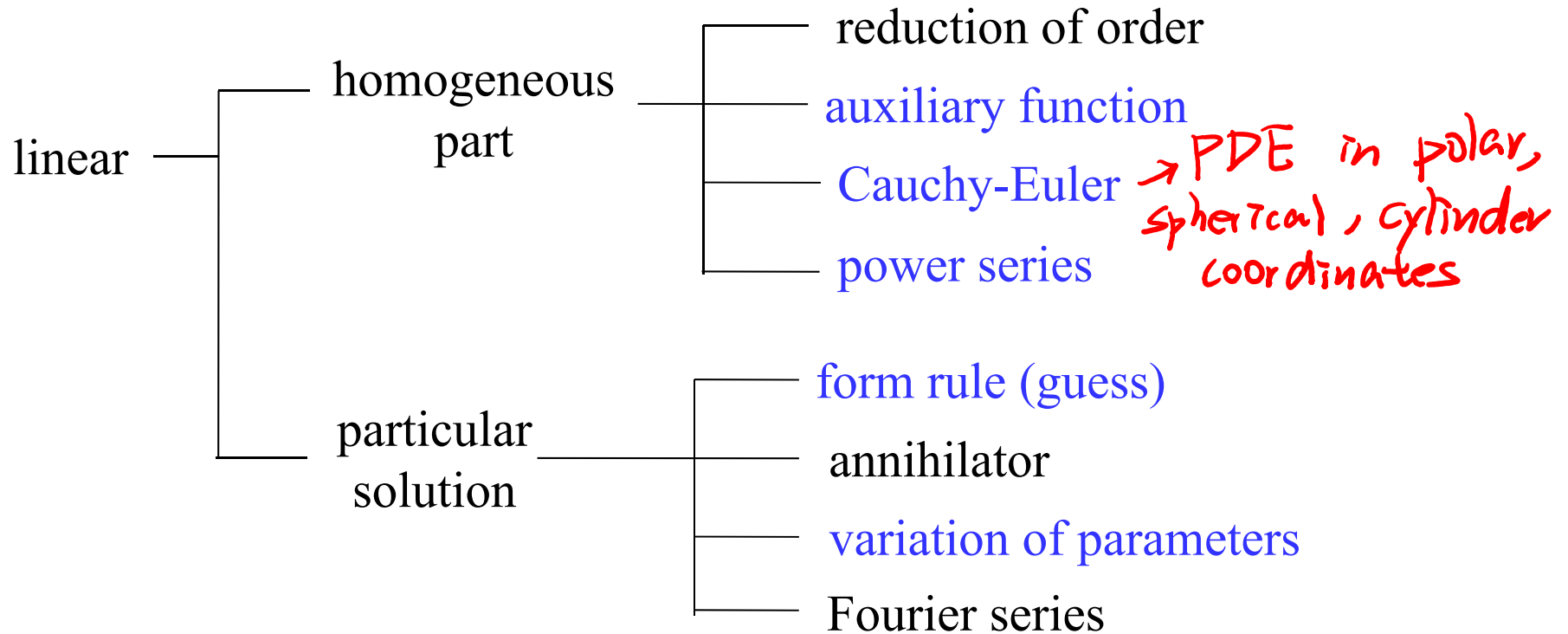

## Architecture for Solving Higher-Order Linear DEs

### Nonhomogeneous **linear** DE

$$a_n(x)y^{(n)}(x) + a_{n-1}(x)y^{(n-1)}(x) + \cdots + a_1(x)y'(x) + a_0(x)y = g(x)$$

Part 1

#### Associated homogeneous DE

$$a_n(x)y^{(n)}(x) + a_{n-1}(x)y^{(n-1)}(x) + \cdots + a_1(x)y'(x) + a_0(x)y = 0$$

find  **$n$  linearly independent solutions**

$$y_1(x), y_2(x), \dots, y_n(x)$$

General solution of this part:

$$y_c(x) = c_1y_1(x) + c_2y_2(x) + \cdots + c_ny_n(x)$$

Part 2

particular solution  $y_p$   
(**any** solution of the nonhomogeneous linear DE)

### general solution of the nonhomogeneous linear DE

$$y(x) = y_c(x) + y_p(x) = c_1y_1(x) + c_2y_2(x) + \cdots + c_ny_n(x) + y_p(x)$$

## (A) Linear DE Homogeneous Part 3 大解法

### (1) Reduction of Order (Zill, Section 4-2)

適用情形：2<sup>nd</sup> order, linear,

one non-trivial solution has been known.

$$y_2(x) = y_1(x) \int \frac{e^{-\int P(x)dx}}{y_1^2(x)} dx$$

## (2) Auxiliary Function (Zill, Section 4-3)

$$a_n y^{(n)}(x) + a_{n-1} y^{(n-1)}(x) + \cdots + a_1 y'(x) + a_0 y = 0$$

$$a_n m^n + a_{n-1} m^{n-1} + \cdots + a_1 m + a_0 = 0$$

適用情形：linear, constant coefficients

(i) If  $m_0$  is a root of  $a_n m^n + a_{n-1} m^{n-1} + \cdots + a_1 m + a_0 = 0$

then  $e^{m_0 x}$  is one of the solutions.

(ii) If  $m_0$  is a repeated root and the multiplicity is  $k$

then  $e^{m_0 x}, x e^{m_0 x}, \cdots, x^{k-1} e^{m_0 x}$  are  $k$  of the solutions.

(iii) If there is a pair of complex roots  $\alpha \pm j\beta$

then  $e^{\alpha x} \cos \beta x$  and  $e^{\alpha x} \sin \beta x$  are two of the solutions.

### (3) Cauchy-Euler Equation (Zill, Section 4-7)

$$a_n x^n y^{(n)}(x) + a_{n-1} x^{n-1} y^{(n-1)}(x) + \cdots + a_1 x y'(x) + a_0 y = 0$$

$$a_n \frac{m!}{(m-n)!} + a_{n-1} \frac{m!}{(m-n+1)!} + \cdots + a_1 \frac{m!}{(m-1)!} + a_0 = 0$$

適用情形：linear, Cauchy-Euler DE

$$x^k y^{(k)} \Rightarrow \frac{m!}{(m-k)!} \\ = m(m-1)\cdots(m-k+1)$$

(i) If  $m_0$  is a root of the above equation

then  $x^{m_0}$  is one of the solutions.

(ii) If  $m_0$  is a repeated root and the multiplicity is  $k$

then  $x^{m_0}, x^{m_0} \ln x, \cdots, x^{m_0} (\ln x)^{k-1}$  are  $k$  of the solutions.

(iii) If there is a pair of complex roots  $\alpha \pm j\beta$

then  $x^\alpha \cos(\beta \ln x)$  and  $x^\alpha \sin(\beta \ln x)$  are two of the solutions.

page 36  $\rightarrow$  page 37  
 $x$   $\ln x$

**(4) Power Series (Zill, Chapter 6)**

$$a_n(x)y^{(n)} + a_{n-1}(x)y^{(n-1)} + \cdots + a_1(x)y' + a_0(x)y = g(x)$$

If  $x_0$  is an ordinary point (not a singular point)

$$y(x) = \sum_{n=0}^{\infty} c_n (x - x_0)^n$$

If  $x_0$  is a regular singular point

$$y(x) = \sum_{n=0}^{\infty} c_n (x - x_0)^{n+r}$$

**[Example 4]** (Zill page 137)

(a)  $2y'' - 5y' - 3y = 0$

$$2m^2 - 5m - 3 = 0, \quad m_1 = -1/2, \quad m_2 = 3$$

$$y = c_1 e^{-x/2} + c_2 e^{3x}$$

(b)  $y'' - 10y' + 25y = 0$

$$m^2 - 10m + 25 = 0, \quad m_1 = 5, \quad m_2 = 5$$

$$y = c_1 e^{5x} + c_2 x e^{5x}$$

(c)  $y'' + 4y' + 7y = 0$

$$m^2 + 4m + 7 = 0, \quad m_1 = -2 + i\sqrt{3}, \quad m_2 = -2 - i\sqrt{3}$$

$$y = e^{-2x} (c_1 \cos \sqrt{3}x + c_2 \sin \sqrt{3}x)$$

**[Example 5]** (Zill page 138)

Solve  $y''' + 3y'' - 4y = 0$

$$m^3 + 3m^2 - 4 = 0$$

$$(m - 1)(m^2 + 4m + 4) = 0 \quad m_1 = 1, \quad m_2 = m_3 = -2$$

3 independent solutions:  $e^x, e^{-2x}, xe^{-2x}$

general solution:  $y = c_1 e^x + c_2 e^{-2x} + c_3 x e^{-2x}$

**[Example 6]** (Zill page 167)

$$x^2 y''(x) - 2xy'(x) - 4y = 0$$

$$m(m - 1) - 2m - 4 = 0 \quad m = 4, -1$$

$$m^2 - 3m - 4 = 0, \quad m = 4, -1$$

2 independent solutions:  $x^4, x^{-1}$

general solution:  $y = c_1 x^4 + c_2 x^{-1}$

**[Example 7]** (Zill page 246)

$$y'' - xy = 0$$

Set  $y(x) = \sum_{n=0}^{\infty} c_n x^n$

**Step 1**  $y'' - xy = \sum_{n=2}^{\infty} c_n n(n-1)x^{n-2} - x \sum_{n=0}^{\infty} c_n x^n = 0$

$$\sum_{n=2}^{\infty} c_n n(n-1)x^{n-2} - \sum_{n=0}^{\infty} c_n x^{n+1} = 0$$

set  $k = n - 2$

set  $k = n + 1$

**Step 2 對齊**  $\sum_{k=0}^{\infty} c_{k+2} (k+2)(k+1)x^k - \sum_{k=1}^{\infty} c_{k-1} x^k = 0$

**Step 3**  $2c_2 + \sum_{k=1}^{\infty} [c_{k+2} (k+2)(k+1) - c_{k-1}] x^k = 0$

$$2c_2 + \sum_{k=1}^{\infty} [c_{k+2}(k+2)(k+1) - c_{k-1}]x^k = 0$$

Step 4

$$2c_2 = 0$$

$$c_2 = 0$$

$$c_{k+2}(k+2)(k+1) - c_{k-1} = 0$$

$$\text{或 } c_{k+2} = \frac{c_{k-1}}{(k+2)(k+1)}$$

recurrence relation

 $c_0, c_1$  給定之後

$$k=1 \quad c_3 = \frac{c_0}{2 \cdot 3}$$

$$k=2 \quad c_4 = \frac{c_1}{3 \cdot 4}$$

$$k=3 \quad c_5 = \frac{c_2}{4 \cdot 5} = 0$$

$$k=4 \quad c_6 = \frac{c_3}{5 \cdot 6} = \frac{c_0}{2 \cdot 3 \cdot 5 \cdot 6}$$

$$k=5 \quad c_7 = \frac{c_4}{6 \cdot 7} = \frac{c_1}{3 \cdot 4 \cdot 6 \cdot 7}$$

$$k=6 \quad c_8 = \frac{c_5}{7 \cdot 8} = 0$$

$$k=7 \quad c_9 = \frac{c_6}{8 \cdot 9} = \frac{c_0}{2 \cdot 3 \cdot 5 \cdot 6 \cdot 8 \cdot 9}$$

$$k=8 \quad c_{10} = \frac{c_7}{9 \cdot 10} = \frac{c_1}{3 \cdot 4 \cdot 6 \cdot 7 \cdot 9 \cdot 10}$$

$$k=9 \quad c_{11} = \frac{c_8}{10 \cdot 11} = 0$$

⋮

⋮

group 1  $c_0, c_3, c_6, c_9 \dots = 0$

group 2  $c_1, c_4, c_7, c_{10} \dots$

group 3  $c_2, c_5, c_8, c_{11} \dots$

### Step 5

$$y(x) = \sum_{n=0}^{\infty} c_n x^n = c_0 \left[ 1 + \frac{x^3}{2 \cdot 3} + \frac{x^6}{2 \cdot 3 \cdot 5 \cdot 6} + \frac{x^9}{2 \cdot 3 \cdot 5 \cdot 6 \cdot 8 \cdot 9} + \dots \right] y_1$$

$$+ c_1 \left[ x + \frac{x^4}{3 \cdot 4} + \frac{x^7}{3 \cdot 4 \cdot 6 \cdot 7} + \frac{x^{10}}{3 \cdot 4 \cdot 6 \cdot 7 \cdot 9 \cdot 10} + \dots \right] y_2$$

$$y(x) = c_0 y_1(x) + c_1 y_2(x)$$

$$y_1(x) = 1 + \sum_{k=1}^{\infty} \frac{1}{2 \cdot 3 \dots (3k-1)(3k)} x^{3k}$$

$$y_2(x) = x + \sum_{k=1}^{\infty} \frac{1}{3 \cdot 4 \dots (3k)(3k+1)} x^{3k+1}$$

## (B) Linear DE Particular solution 4 大解法

## (1) Guess (Zill, Section 4-4)

要訣：  $y_p$  should be a linear combination of

$$g(x), g'(x), g''(x), g'''(x), g^{(4)}(x), g^{(5)}(x), \dots$$

form rule

遇到重覆，乘  $x$  或  $\ln x$

適用情形：linear, constant coefficients,  $g^{(n)}(x)$  have finite terms

Glitch Condition: When the form of  $y_p$  is overlapped with the solution of the associated homogeneous DE  $\rightarrow$  multiply  $y_p$  by  $x$

However, if

$$g(x) = \ln x$$

$$g'(x) = \frac{1}{x}$$

$$g''(x) = -\frac{1}{x^2}$$

$$g'''(x) = \frac{2}{x^3}$$

## Trial Particular Solutions (from Zill's textbook, page 146)

$g(x)$	Form of $y_p$
1 (any constant)	$A$
$5x + 7$	$Ax + B$
$3x^2 - 2$	$Ax^2 + Bx + C$
$x^3 - x + 1$	$Ax^3 + Bx^2 + Cx + E$
$\sin 4x$	$A\cos 4x + B\sin 4x$
$\cos 4x$	$A\cos 4x + B\sin 4x$
$e^{5x}$	$Ae^{5x}$
$(9x - 2)e^{5x}$	$(Ax + B)e^{5x}$
$x^2e^{5x}$	$(Ax^2 + Bx + C)e^{5x}$
$e^{3x}\sin 4x$	$Ae^{3x}\cos 4x + Be^{3x}\sin 4x$
$5x^2\sin 4x$	$(Ax^2 + Bx + C)\cos 4x + (Ex^2 + Fx + G)\sin 4x$
$xe^{3x}\cos 4x$	$(Ax + B)e^{3x}\cos 4x + (Cx + E)e^{3x}\sin 4x$



It comes from the “**form rule**”.

**(2) Annihilator (Zill, Section 4-5)**

若原本的 DE 為  $L[y(x)] = g(x)$     Annihilator:  $L_1[g(x)] = 0$

Particular solution 為  $L_1\{L[y(x)]\} = 0$  的解

(扣去和  $L[y(x)] = 0$  的解重複的部分)

$$y = y_c + y_p$$

適用情形：linear, constant coefficients,  $g^{(n)}(x)$  have finite terms

### (3) Variation of parameters (Zill, Section 4-6)

適用情形：Any linear DE

Standard form:

$$y^{(n)}(x) + \frac{a_{n-1}(x)}{a_n(x)} y^{(n-1)}(x) + \cdots + \frac{a_1(x)}{a_n(x)} y'(x) + \frac{a_0(x)}{a_n(x)} y = \frac{g(x)}{a_n(x)}$$

Suppose that the  $n$  linearly independent solutions of the associated homogeneous equation are:

$$y_1(x), y_2(x), \cdots, y_n(x)$$

Particular solution:

$$y_p = u_1 y_1 + u_2 y_2 + \cdots + u_n y_n$$

$$y_p = u_1 y_1 + u_2 y_2 + \cdots + u_n y_n$$

$$u'_k(x) = \frac{W_k}{W}$$

$u_k(x) = \int \frac{W_k}{W}$

$W = \det$

determinant

$$\begin{bmatrix} y_1 & y_2 & y_3 & \cdots & y_n \\ y_1' & y_2' & y_3' & \cdots & y_n' \\ y_1'' & y_2'' & y_3'' & \cdots & y_n'' \\ \vdots & \vdots & \vdots & \ddots & \vdots \\ y_1^{(n-1)} & y_2^{(n-1)} & y_3^{(n-1)} & \cdots & y_n^{(n-1)} \end{bmatrix}$$

$W_k$ : replace the  $k^{\text{th}}$  column of  $W$  by

$$f(x) = \frac{g(x)}{a_n(x)}$$

$$\begin{bmatrix} 0 \\ 0 \\ \vdots \\ 0 \\ f(x) \end{bmatrix}$$

**(4) Fourier series (Zill, Section 11-3)**

$$a_n y^{(n)}(t) + a_{n-1} y^{(n-1)}(t) + \cdots + a_1 y'(t) + a_0 y(t) = f(t)$$

$$f(t) = f(t + 2p)$$

Trying to express  $f(t)$  as

$$f(t) = \frac{a_0}{2} + \sum_{n=1}^{\infty} \left( a_n \cos \frac{n\pi}{p} t + b_n \sin \frac{n\pi}{p} t \right)$$

Then, suppose that the particular solution is

$$y_p(t) = A_0 + \sum_{n=1}^{\infty} \left( A_n \cos \frac{n\pi}{p} t + B_n \sin \frac{n\pi}{p} t \right)$$

適用情形：periodic,  
being able to transformed by the Fourier series

**[Example 8]** (Zill page 144)

$$y'' - y' + y = 2 \sin 3x$$

Step 1: find the solution of the associated homogeneous equation

Guess

Step 2: particular solution

$$y_p = A \cos 3x + B \sin 3x$$

$$y'_p = -3A \sin 3x + 3B \cos 3x$$

$$y''_p = -9A \cos 3x - 9B \sin 3x$$

$$y''_p - y'_p + y_p = (-8A - 3B) \cos 3x + (3A - 8B) \sin 3x = 2 \sin 3x$$

$$\begin{cases} -8A - 3B = 0 \\ 3A - 8B = 2 \end{cases}$$

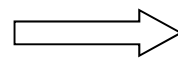

$$A = 6/73, B = -16/73$$

$$y_p = \frac{6}{73} \cos 3x - \frac{16}{73} \sin 3x$$

Step 3: General solution:

$$y = e^{x/2} \left( c_1 \cos \frac{\sqrt{3}}{2} x + c_2 \sin \frac{\sqrt{3}}{2} x \right) + \frac{6}{73} \cos 3x - \frac{16}{73} \sin 3x$$

$$y'' - y' + y = 0$$

auxiliary  $m^2 - m + 1 = 0$

$$m = \frac{1 \pm i\sqrt{3}}{2}$$

$$y_c = e^{x/2} \left( c_1 \cos \frac{\sqrt{3}}{2} x + c_2 \sin \frac{\sqrt{3}}{2} x \right)$$

**[Example 9]**  $y'' - 5y' + 4y = 8e^x$  (text page 146)

Particular solution guessed by Form Rule:

$$y_p = Ae^x$$

$$y_p'' - 5y_p' + 4y_p = Ae^x - 5Ae^x + 4Ae^x = 8e^x$$

$$0 = 8e^x \quad (\text{no solution})$$

Since  $y_c = c_1e^x + c_2e^{4x}$        $Ae^x \in y_c$

解決方法：再乘一個  $x$

$$y_p = Axe^x \quad y_p' = Axe^x + Ae^x$$

$$y_p'' = Axe^x + 2Ae^x$$

$$y_p'' - 5y_p' + 4y_p = -3Ae^x = 8e^x \implies A = -8/3$$

$$y_p = -\frac{8}{3}xe^x$$

$$y = c_1e^x + c_2e^{4x} - \frac{8}{3}xe^x$$

Until now, only a small part of DEs can be solved.

## 1-2 Numerical Methods

Even if it can be shown that a solution of a differential equation exists, we might not be able to exhibit it in an explicit or implicit form.

D. G. Zill and Michael R. Cullen, *Differential Equations-with Boundary-Value Problem (metric version)*, 9th edition, Cengage Learning, 2017.  
(Sections 2-6, 9-1, 9-2)

## 1-2-1 Euler's Method

- independent variable  $x$   $\xrightarrow{\text{sampling(取樣)}}$   $x_0, x_1, x_2, \dots$

- Find the solution of  $\frac{dy(x)}{dx} = f(x, y)$    
 *slope of  $y(x)$*

Since  $\frac{dy(x)}{dx} = f(x, y)$   $\xrightarrow{\text{approximation}}$   $\frac{y(x_{n+1}) - y(x_n)}{x_{n+1} - x_n} = f(x_n, y(x_n))$

$$y(x_{n+1}) = y(x_n) + \underbrace{f(x_n, y(x_n))}_{\text{slope of } y(x) \text{ at } x=x_n} (x_{n+1} - x_n)$$

前一點的值

取樣間格

*slope of  $y(x)$  at  $x=x_n$*

$$\begin{aligned} & \text{If } x_{n+1} - x_n \cong 0 \\ & \left. \frac{y(x_{n+1}) - y(x_n)}{x_{n+1} - x_n} \cong \frac{dy(x)}{dx} \right|_{x=x_n} \end{aligned}$$

$$\frac{dy(x)}{dx} = f(x, y)$$

$$y(x_{n+1}) = y(x_n) + f(x_n, y(x_n))h$$

$$h = x_{n+1} - x_n$$

If  $y(x_0)$  is known

$$\text{for } n = 0: \quad y(x_1) = y(x_0) + f(x_0, y(x_0))(x_1 - x_0)$$

$$\text{for } n = 1: \quad y(x_2) = y(x_1) + f(x_1, y(x_1))(x_2 - x_1)$$

$$\text{for } n = 2: \quad y(x_3) = y(x_2) + f(x_2, y(x_2))(x_3 - x_2)$$

⋮  
⋮  
⋮  
⋮  
⋮

$$\frac{dy(x)}{dx} = f(x, y)$$

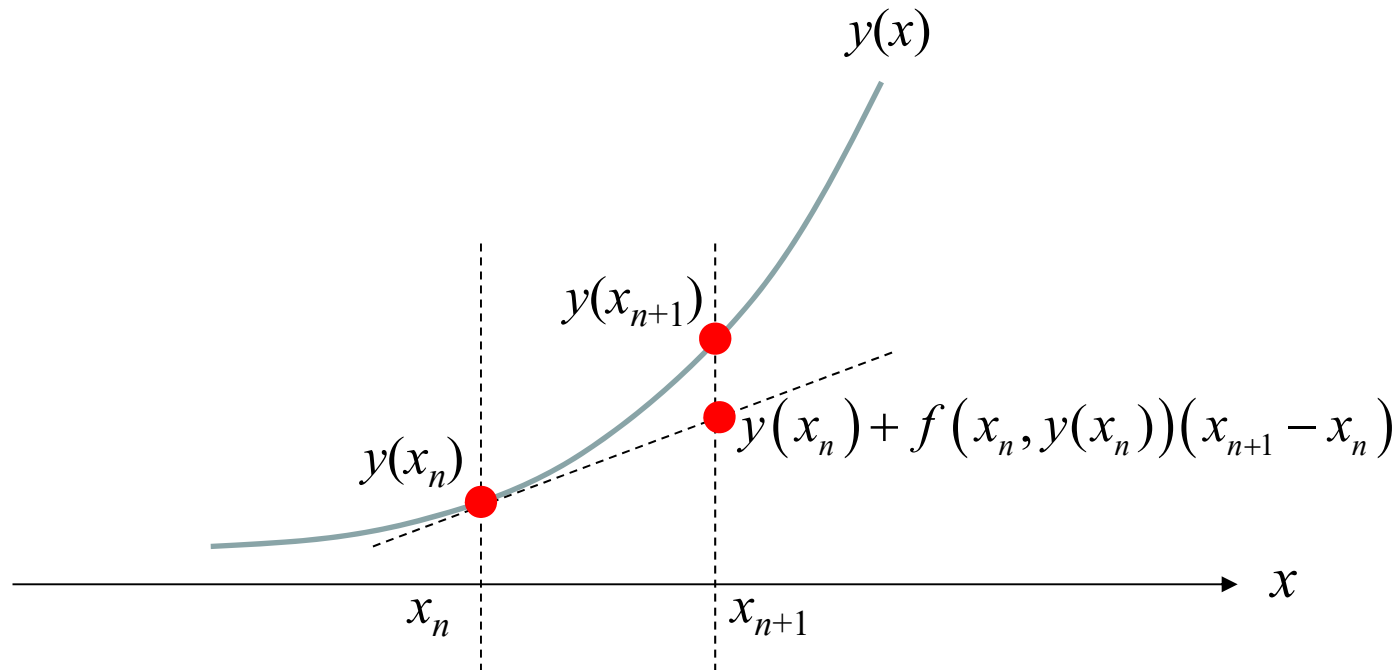

**Problem:** Can we modify the slope when determining  $y(x_{n+1})$ ?

$$\frac{dy(x)}{dx} = f(x, y)$$

$$y(x_{n+1}) = y(x_n) + f(x_n, y(x_n))h$$

$$h = x_{n+1} - x_n$$

**[Example 1]** (Zill page 371)

$$y' = 2xy, y(1) = 1$$

$$\text{slope} = 2xy \quad x_0 = 1 \quad y(x_0) = 1$$

In this case,  $f(x, y) = 2xy$

$$y(x_{n+1}) = y(x_n) + 2x_n y(x_n)h$$

From the Taylor series

$$y(x) = y(a) + \underbrace{y'(a)}_{\text{slope } f(x,y)} \frac{x-a}{1!} + \dots + y^{(k)}(a) \frac{(x-a)^k}{k!} + y^{(k+1)}(c) \frac{(x-a)^{k+1}}{(k+1)!}$$

$$y(x_{n+1}) = \underbrace{y_n + hf(x_n, y_n)}_{y_{n+1}} + \underbrace{y''(c) \frac{h^2}{2!}}_{\text{2nd term}}$$

The local truncation error in  $y_{n+1}$  is  $y''(c) \frac{h^2}{2!} = O(h^2)$

Global error:  $O(h)$

Large  $h \rightarrow$  Large error

(Their definitions can be seen from the next page)

The local truncation error: The error to compute the next iteration.

Global error: The error at the same point.

The local truncation error  $\times \frac{L}{h}$  = the global error

$\mathcal{O}(h^2)$

$$h^2 \times \frac{L}{h} = Lh \mathcal{O}(h)$$

$L$ : distance between start  
end points

$L/h$ : number of iterations

Zill **TABLE 9.1.1** Euler's Method with  $h = 0.1$ 

$x_n$	$y_n$	Actual value	Abs. error	% Rel. error
1.00	1.0000	1.0000	0.0000	0.00
1.10	1.2000	1.2337	0.0337	2.73

Zill **TABLE 9.1.2** Euler's Method with  $h = 0.05$ 

$x_n$	$y_n$	Actual value	Abs. error	% Rel. error
1.00	1.0000	1.0000	0.0000	0.00
1.05	1.1000	1.1079	0.0079	0.72
1.10	1.2155	1.2337	0.0182	1.47

Large  $h \rightarrow$  Large error

## 1-2-2 Improved Euler's Method

$$\frac{dy(x)}{dx} = f(x, y)$$

$$y_{n+1}^* = y_n + hf(x_n, y_n),$$

1<sup>st</sup> estimation of  $y_{n+1}$

$$y_{n+1} = y_n + h \frac{f(x_n, y_n) + f(x_{n+1}, y_{n+1}^*)}{2},$$

2<sup>nd</sup> estimation of  $y_{n+1}$

$n = n+1$

*same as Euler's method*

*slope at  $x_n$       estimated slope at  $x_{n+1}$*

where  $y_n = y(x_n), \quad y_{n+1} = y(x_{n+1}) \quad h = x_{n+1} - x_n$

$y_{n+1}^*$  is the first estimation for  $y_{n+1}$

local truncation error:  $\mathcal{O}(h^3)$

global error:  $\mathcal{O}(h^3 \times \frac{L}{h}) = \mathcal{O}(Lh^2) = \mathcal{O}(h^2)$

Zill **TABLE 9.1.3** Improved Euler's Method with  $h = 0.1$ 

	$x_n$	$y_n$	Actual value	Abs. error	% Rel. error
<b>initial</b>	1.00	1.0000	1.0000	0.0000	0.00
<b><math>n = 1</math></b>	1.10	1.2320	1.2337	0.0017	0.14

Zill **TABLE 9.1.4** Improved Euler's Method with  $h = 0.05$ 

	$x_n$	$y_n$	Actual value	Abs. error	% Rel. error
<b>initial</b>	1.00	1.0000	1.0000	0.0000	0.00
<b><math>n = 1</math></b>	1.05	1.1077	1.1079	0.0002	0.02
<b><math>n = 2</math></b>	1.10	1.2332	1.2337	0.0004	0.04

The errors are much less than those of Euler's method.

Local truncation error for the improved Euler's method is  $O(h^3)$ , the global truncation error is  $O(h^2)$ .

## 1-2-3 Runge-Kutta Methods

General form of the Runge-Kutta (RK) method.

$$y_{n+1} = y_n + h \overbrace{(w_1 k_1 + w_2 k_2 + \dots + w_m k_m)}^{\text{weighted average}} \rightarrow \text{weighted sum of } m \text{ estimated slopes}$$

$$w_1 + w_2 + \dots + w_m = 1, \quad k_1 = f(x_n, y_n)$$

$k_2, \dots, k_m$ : the values of  $f(x, y)$  between  $(x_n, y_n)$  and  $(x_{n+1}, y_{n+1})$   
slope

Euler's method is said to be a **first-order Runge-Kutta method (RK1)**.

Improved Euler's method is said to be a **second-order Runge-Kutta method (RK2)**.  $m=2, w_1 = w_2 = \frac{1}{2}$

## A Fourth-Order Runge-Kutta Method (RK4)

$$\frac{dy(x)}{dx} = f(x, y)$$

$$y_n = y(x_n) \quad y_{n+1} = y(x_{n+1}) \quad x_{n+1} = x_n + h$$

$$y_{n+1} = y_n + h(w_1 k_1 + w_2 k_2 + w_3 k_3 + w_4 k_4).$$

$$k_1 = f(x_n, y_n)$$

$$k_2 = f(x_n + \alpha_1 h, y_n + \alpha_1 h k_1)$$

estimated  $y(x_n + \alpha_1 h)$

$$k_3 = f(x_n + \alpha_2 h, y_n + \alpha_2 h((1 - c_1)k_1 + c_1 k_2))$$

estimated  $y(x_n + \alpha_2 h)$

$c_1 = 1$

$$k_4 = f(x_n + \alpha_3 h, y_n + \alpha_3 h((1 - c_2 - c_3)k_1 + c_2 k_2 + c_3 k_3))$$

$c_2 = 0, c_3 = 1$

estimated  $y(x_n + \alpha_3 h)$

where  $w_1 + w_2 + w_3 + w_4 = 1$

$k_2$ : estimated slope at  $x_n + \alpha_1 h$

$k_3$ : estimated slope at  $x_n + \alpha_2 h$

$k_4$ : estimated slope at  $x_n + \alpha_3 h$

$$0 < \alpha_1 \leq \alpha_2 < \alpha_3 \leq 1$$

**RK4 method**

$$\alpha_1 = \alpha_2 = 1/2, \quad \alpha_3 = 1$$

$$c_1 = 1, \quad c_2 = 0, \quad c_3 = 1$$

$$w_1 = w_4 = 1/6, \quad w_2 = w_3 = 2/6$$

$$\begin{aligned}
 k_1 &= f(x_n, y_n) \\
 k_2 &= f\left(x_n + \frac{1}{2}h, y_n + \frac{1}{2}hk_1\right) \\
 k_3 &= f\left(x_n + \frac{1}{2}h, y_n + \frac{1}{2}hk_2\right) \\
 k_4 &= f(x_n + h, y_n + hk_3) \\
 y_{n+1} &= y_n + \frac{h}{6}(k_1 + 2k_2 + 2k_3 + k_4), \\
 n &= n + 1
 \end{aligned}$$

It is also named as the fourth-order Runge-Kutta method (the RK4 method) or the classical Runge-Kutta method.

$k_1$  is determined at  $x_n$

$k_2, k_3$  are estimated at  $x_n + h/2$

$k_4$  is estimated at  $x_n + h$

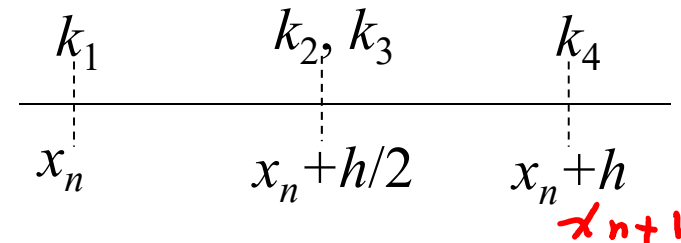

**[Example 2]** (Zill page 375) RK4 Method

Use the RK4 method with  $h = 0.1$  to obtain an approximation to  $y(1.5)$  for the solution of

$$y' = 2xy, \quad y(1) = 1.$$

**SOLUTION**

For the sake of illustration, let us compute the case when  $n = 0$ .

$$k_1 = f(x_0, y_0) = 2x_0y_0 = 2 \qquad \text{Note: } f(x, y) = 2xy$$

$$\begin{aligned} k_2 &= f\left(x_0 + \frac{1}{2}(0.1), y_0 + \frac{1}{2}(0.1)2\right) \\ &= 2\left(x_0 + \frac{1}{2}(0.1)\right)\left(y_0 + \frac{1}{2}(0.2)\right) = 2.31 \end{aligned}$$

$$\begin{aligned} k_3 &= f\left(x_0 + \frac{1}{2}(0.1), y_0 + \frac{1}{2}(0.1)2.31\right) \\ &= 2\left(x_0 + \frac{1}{2}(0.1)\right)\left(y_0 + \frac{1}{2}(0.231)\right) = 2.34255 \end{aligned}$$

$$\begin{aligned} k_4 &= f(x_0 + (0.1), y_0 + (0.1)2.34255) \\ &= 2(x_0 + 0.1)(y_0 + 0.234255) = 2.715361 \end{aligned}$$

And therefore,

$$\begin{aligned}
 y_1 &= y_0 + \frac{0.1}{6}(k_1 + 2k_2 + 2k_3 + k_4) \\
 &= 1 + \frac{0.1}{6}(2 + 2(2.31) + 2(2.34255) + 2.715361) = 1.23367435.
 \end{aligned}$$

**TABLE 9.2.1** RK4 Method with  $h = 0.1$

$x_n$	$y_n$	Actual value	Abs. error	% Rel. error
1.00	1.0000	1.0000	0.0000	0.00
1.10	1.2337	1.2337	0.0000	0.00
1.20	1.5527	1.5527	0.0000	0.00
1.30	1.9937	1.9937	0.0000	0.00
1.40	2.6116	2.6117	0.0001	0.00
1.50	3.4902	3.4904	0.0001	0.00

The remaining calculations are summarized in Table 9.2.1, whose entries are rounded to four decimal places.

much more accurate

Comparison of numerical methods with  $h = 0.05$

$x_n$	Euler	Improved Euler	RK4	Actual value
1.00	1.0000	1.0000	1.0000	1.0000
1.05	1.1000	1.1077	1.1079	1.1079
1.10	1.2155	1.2332	1.2337	1.2337
1.15	1.3492	1.3798	1.3806	1.3806
1.20	1.5044	1.5514	1.5527	1.5527
1.25	1.6849	1.7531	1.7551	1.7551
1.30	1.8955	1.9909	1.9937	1.9937
1.35	2.1419	2.2721	2.2762	2.2762
1.40	2.4311	2.6060	2.6117	2.6117
1.45	2.7714	3.0038	3.0117	3.0117
1.50	3.1733	3.4795	3.4903	3.4904

The local truncation error for this method is  $y^{(5)}(c)h^5 / 5!$  or  $O(h^5)$ , and the global truncation error is thus  $O(h^4)$ .

$$O\left(h^5 \times \frac{L}{h}\right) = O(h^4)$$

[Detail of proof of the RK4 method]:

<https://math.stackexchange.com/questions/2636121/prove-that-runge-kutta-method-rk4-is-of-order-4>

## 1-3 Nonlinear Differential Equations

Method 1: Reduction of Order

Method 2: Taylor Series

Method 3: Numerical Approach

D. G. Zill and Michael R. Cullen, Differential Equations-with Boundary-Value Problem (metric version), 9th edition, Cengage Learning, 2017.  
(Section 4-10)

## 1-3-1 Method 1: Reduction of Order

精神：變成 1<sup>st</sup> order DE

再用 1<sup>st</sup> order DE 的方法求解

限制：The DE should have the form of

Case 1, pages 71-72

$$F\left(x, \frac{d}{dx}y, \frac{d^2}{dx^2}y\right) = 0$$

(Without the term  $y$ )

$$u \quad \frac{d}{dx}u$$

or

Case 2, pages 73-75

$$F\left(y, \frac{d}{dx}y, \frac{d^2}{dx^2}y\right) = 0$$

(Without the term  $x$ )

$y$ : independent variable

$$u(y) \frac{d}{dy}u(y)$$

$$u \frac{du}{dy}$$

Case 1: The 2<sup>nd</sup> order DE has the form of  $F\left(x, \frac{d}{dx}y, \frac{d^2}{dx^2}y\right) = 0$   
(Without the term  $y$ )

$u$        $\frac{d}{dx}u$

解法：(Step 1) Set  $u = \frac{d}{dx}y$

此時DE 變成  $F\left(x, u, \frac{d}{dx}u\right) = 0$  (對  $u$  而言，是 1<sup>st</sup> order DE)

(Step 2) 將  $u$  解出來 (用 1<sup>st</sup> Order DE 的方法)

(Step 3) 對  $u$  作積分，即解出  $y$

**[Example 1]** (Zill page 189)

$$y'' = 2x(y')^2$$

(Step 1)  $u = y'$       $u = \frac{d}{dx}y$       $\frac{d^2}{dx^2}y = \frac{d}{dx}u$

$\frac{d}{dx}u = 2xu^2$      separation of variables (page 27)      $\frac{du}{u^2} = 2x dx$   
 $-u^{-1} = x^2 + C$

(Step 2)  $u = -\frac{1}{x^2 + c}$

(Step 3)  $y = -\int \frac{1}{x^2 + c} dx = ?$      page 11  
 $-\frac{1}{\sqrt{c}} \tan^{-1}\left(\frac{x}{\sqrt{c}}\right) + C_1$

Case 2: The 2<sup>nd</sup> order DE has the form of  $F\left(y, \frac{d}{dx}y, \frac{d^2}{dx^2}y\right) = 0$

(Without the term  $x$ )

$u$        $u \frac{d}{dy}u$

解法：(Step 1) Set  $u = \frac{d}{dx}y$

$$\frac{d^2}{dx^2}y = \frac{d}{dx}u = \frac{dy}{dx} \frac{d}{dy}u = u \frac{d}{dy}u \quad (\text{Chain rule})$$

此時DE 變成  $F\left(y, u, u \frac{d}{dy}u\right) = 0$

(對  $u$  而言，是 1<sup>st</sup> order DE, independent variable 為  $y$ )

(Step 2) 將  $u$  解出來 (用 1<sup>st</sup> Order DE 的方法)

得出的解,  $u$  是  $y$  的函數  $u = F_1(y)$

(Step 3)  $\frac{dy}{dx} = F_1(y) \quad \frac{dy}{F_1(y)} = dx$

用 separable variable 的方法即可將解得出

**[Example 2]** (Zill page 190)

$$yy'' = (y')^2$$

(Step 1) Set  $u = \frac{d}{dx}y$

$$y \cdot u \frac{d}{dy}u = u^2$$

1st order  
separable variables

(Step 2)  $\frac{du}{u} = \frac{dy}{y}$        $\ln|u| = \ln|y| + c_1$        $|u| = |y|e^{c_1}$

$$u = c_2y \quad (c_2 = \pm e^{c_1})$$

(Step 3)  $\frac{dy}{dx} = c_2y$        $\frac{dy}{y} = c_2dx$        $\ln|y| = c_2x + c_3$        $|y| = e^{c_2x}e^{c_3}$

1st order, separable variables

$$y = c_4e^{c_2x} \quad (c_4 = \pm e^{c_3})$$

## 1-3-2 Method 2: Taylor Series

$$y(x) = y(0) + \frac{y'(0)}{1!}x + \frac{y''(0)}{2!}x^2 + \frac{y'''(0)}{3!}x^3 + \frac{y^{(4)}(0)}{4!}x^4 + \dots$$

更一般化的型態

$$y(x) = y(x_0) + \frac{y'(x_0)}{1!}(x-x_0) + \frac{y''(x_0)}{2!}(x-x_0)^2 + \frac{y'''(x_0)}{3!}(x-x_0)^3 + \\ + \frac{y^{(4)}(x_0)}{4!}(x-x_0)^4 + \dots$$

Step 1 算出  $y(x_0)$ ,  $y'(x_0)$ ,  $y''(x_0)$ ,  $y'''(x_0)$ ,  $y^{(4)}(x_0)$ ,  $\dots$

Step 2 代回 Taylor series

**[Example 3]** (Zill page 190)

$$x_0 = 0$$

$$y'' = x + y - y^2 \quad y(0) = -1 \quad y'(0) = 1$$

$$y'' = x + y - y^2 \quad y''(0) = 0 + (-1) - (-1)^2 = -2$$

$$y''' = \frac{d}{dx}(x + y - y^2) = 1 + y' - 2y'y' \quad y'''(0) = 4$$

$$y^{(4)} = \frac{d}{dx}(1 + y' - 2y'y') = y'' - 2y''y - 2(y')^2 \quad y^{(4)}(0) = -8$$

$$y^{(5)} = \frac{d}{dx}(y'' - 2y''y - 2(y')^2) = y''' - 2y'''y - 6y'y'' \quad y^{(5)}(0) = 24$$

:

代回 Taylor series

$$y(x) = -1 + x - x^2 + \frac{2}{3}x^3 - \frac{1}{3}x^4 + \frac{1}{5}x^5 \dots$$

限制：(1)  $y(x)$  在  $x_0$  的地方必需為 analytic,

( $x = x_0$  不為 singular point)

(2) 在解  $n^{\text{th}}$  order DE 時， $y(x_0)$ ， $y'(x_0)$ ， $y''(x_0)$ ，.....

$y^{(n-1)}(x_0)$  的值必需皆為已知

(3) 得出的解只有在  $x_0$  附近較為正確

問題：(1) Taylor series 應該取多少項？

(2)  $|x - x_0|$  的範圍？

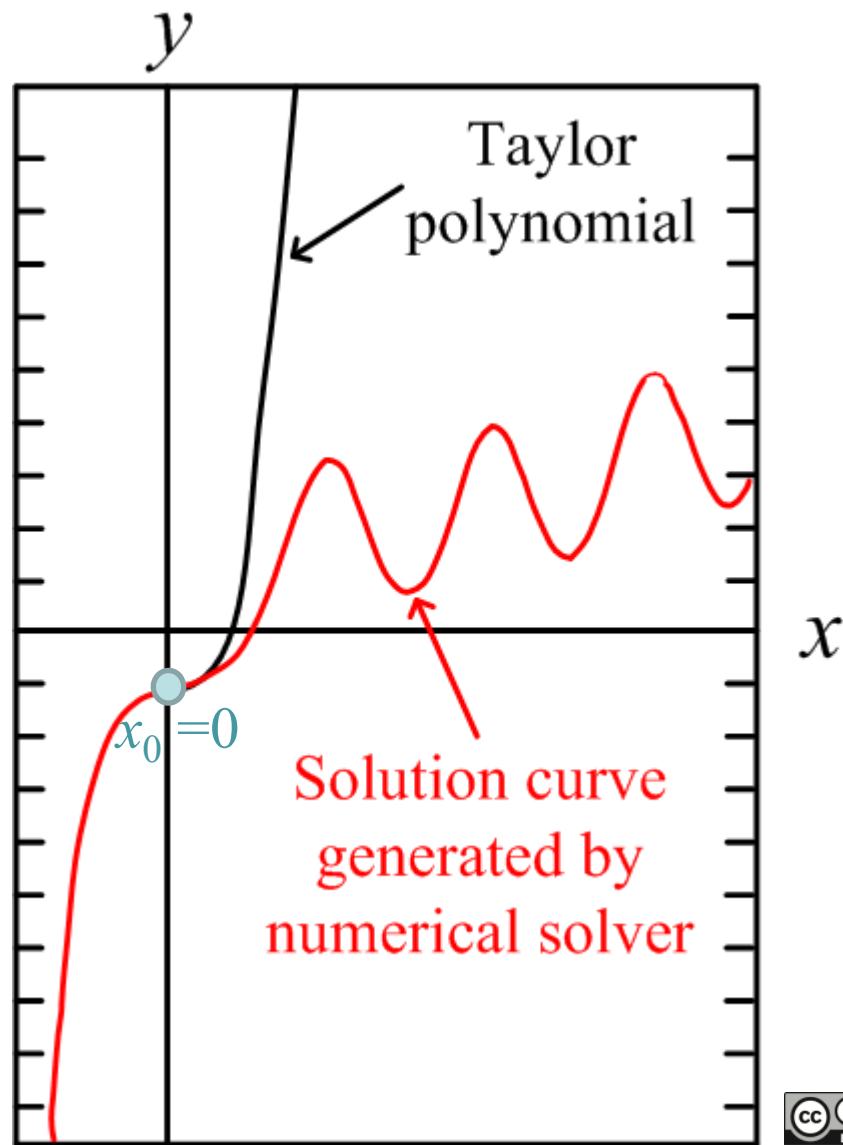

### 1-3-3 Method 3: Numerical Method

複習

Numerical Method for the 1<sup>st</sup> Order DE

$$\frac{dy(x)}{dx} = f(x, y) \longrightarrow \frac{y(x_{n+1}) - y(x_n)}{x_{n+1} - x_n} = f(x_n, y(x_n))$$

$$y(x_{n+1}) = y(x_n) + \underline{f(x_n, y(x_n))(x_{n+1} - x_n)}$$

1 2<sup>nd</sup> order DE  $\Rightarrow$  2 1<sup>st</sup> order DEs

81

$$\frac{d^2 y}{dx^2} = f(x, y, y') \quad y(x_0) = y_0 \quad y'(x_0) = u_0$$

解法  $\begin{cases} \underline{y' = u} \\ u' = f(x, y, u) \end{cases}$  subject to  $y(x_0) = y_0, \quad u(x_0) = u_0$

Use Euler's Method

$$y(x_{n+1}) = y(x_n) + (x_{n+1} - x_n)y'(x_n)$$

$$\begin{cases} y(x_{n+1}) = y(x_n) + (x_{n+1} - x_n)u(x_n) \\ u(x_{n+1}) = u(x_n) + (x_{n+1} - x_n)u'(x_n) \\ \quad = u(x_n) + (x_{n+1} - x_n)f(x_n, y(x_n), u(x_n)) \end{cases}$$

$$\begin{cases} y' = u \\ u' = f(x, y, u) \end{cases} \quad y(x_0) = y_0, \quad u(x_0) = u_0$$

Recursive 的解法 (Euler's Method)

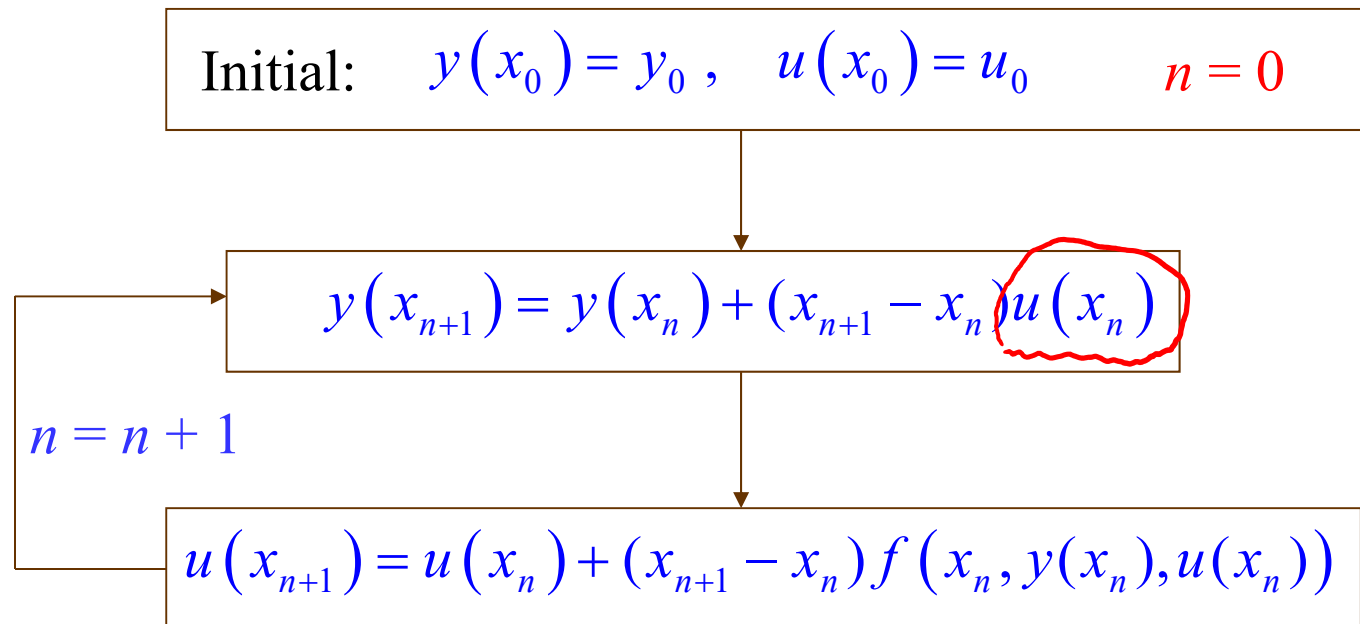

$$\begin{cases} y' = u \\ u' = f(x, y, u) \end{cases} \quad y(x_0) = y_0, \quad u(x_0) = u_0$$

Recursive 的解法 (Modified Euler's Method) *RK2*

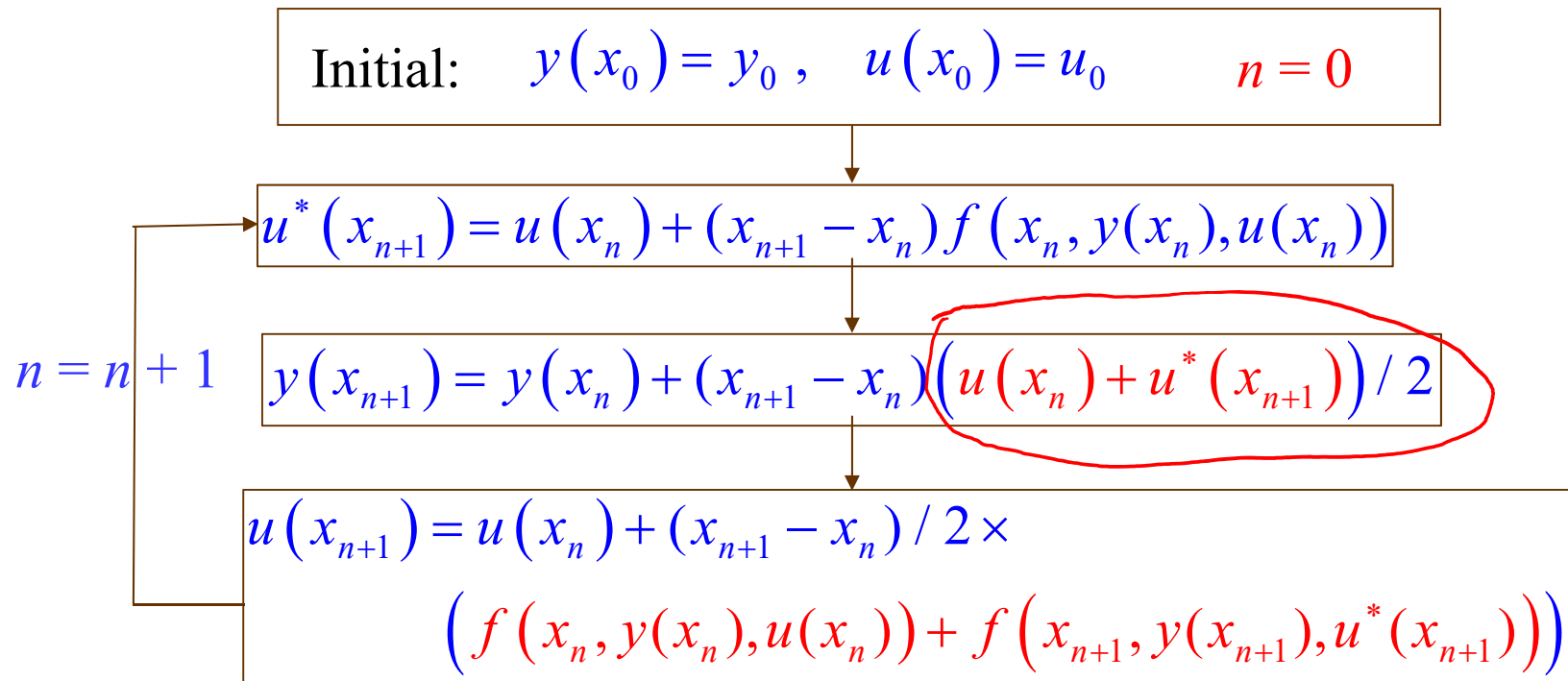

$$\begin{cases} y' = u \\ u' = f(x, y, u) \end{cases} \quad y(x_0) = y_0, \quad u(x_0) = u_0 \quad x_{n+1/2} = x_n + \frac{(x_{n+1} - x_n)}{2}$$

Recursive 的解法 (RK4)

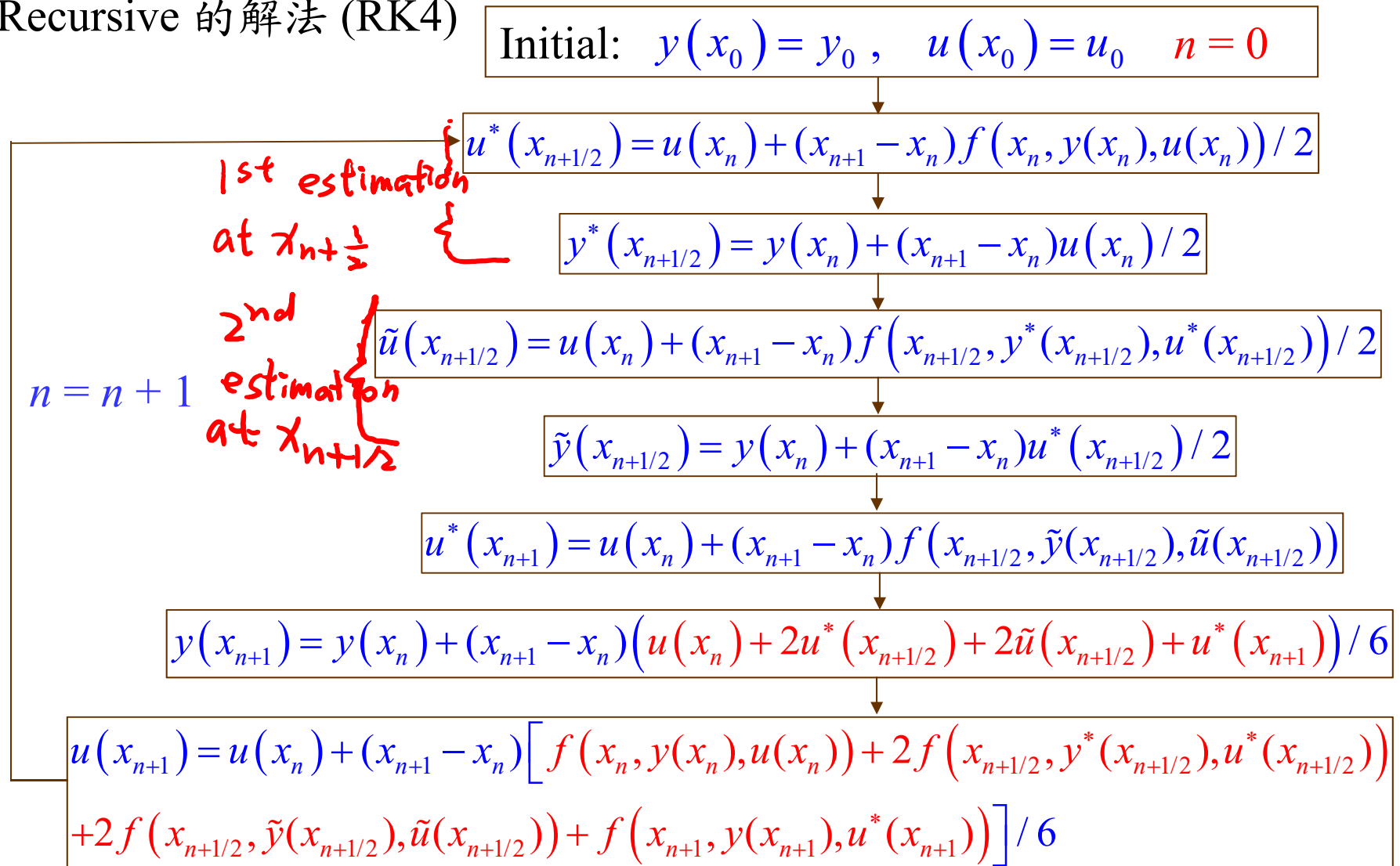

$k^{\text{th}}$  order DE  $\Rightarrow$   $k$  1<sup>st</sup> order DEs 85

更一般化的情形

$$\frac{d^k y}{dx^k} = f(x, y, y', y'', \dots, y^{(k-1)})$$

$$y(x_0) = y_{0,0} \quad y'(x_0) = y_{0,1} \quad y''(x_0) = y_{0,2} \quad \dots$$

$$y^{(k-1)}(x_0) = y_{0,k-1}$$

改變為

$$\left\{ \begin{array}{l} y' = u_1 \\ u_1' = y'' = u_2 \\ u_2' = y''' = u_3 \\ \vdots \\ u_{k-2}' = y^{(k-1)} = u_{k-1} \\ u_{k-1}' = f(x, y, u_1, u_2, \dots, u_{k-1}) \end{array} \right. \quad \text{subject to} \quad \begin{array}{l} y(x_0) = y_{0,0} \\ u_1(x_0) = y_{0,1} \\ u_2(x_0) = y_{0,2} \\ \vdots \\ u_{k-1}(x_0) = y_{0,k-1} \end{array}$$

## Recursive 的解法 (Euler)

$$\text{Initial: } y(x_0) = y_{0,0}, \quad u_1(x_0) = y_{0,1}, \quad u_2(x_0) = y_{0,2}, \\ \dots\dots, u_{k-1}(x_0) = y_{0,k-1}, \quad n = 0$$

$$y(x_{n+1}) = y(x_n) + (x_{n+1} - x_n)u_1(x_n) \quad y' = u_1$$

$$u_1(x_{n+1}) = u_1(x_n) + (x_{n+1} - x_n)u_2(x_n) \quad u'_1 = u_2$$

$$u_2(x_{n+1}) = u_2(x_n) + (x_{n+1} - x_n)u_3(x_n) \quad u'_2 = u_3$$

$$u_{k-2}(x_{n+1}) = u_{k-2}(x_n) + (x_{n+1} - x_n)u_{k-1}(x_n) \quad u'_{k-2} = u_{k-1}$$

$$u_{k-1}(x_{n+1}) = u_{k-1}(x_n) + (x_{n+1} - x_n)f(x_n, y(x_n), u_1(x_n), u_2(x_n), \dots, u_{k-1}(x_n))$$

$$u'_{k-1} = f(x, y, u_1, u_2, \dots, u_{k-1})$$

$n = n + 1$

# Recursive 的解法 (Modified Euler Method)

Initial:  $y(x_0) = y_{0,0}, u_1(x_0) = y_{0,1}, u_2(x_0) = y_{0,2},$   
 $\dots\dots, u_{k-1}(x_0) = y_{0,k-1}, \quad n = 0$

$n = n + 1$   
 1st  
 estimation

$$u_1^*(x_{n+1}) = u_1(x_n) + (x_{n+1} - x_n)u_2(x_n)$$

$$u_{k-2}^*(x_{n+1}) = u_{k-2}(x_n) + (x_{n+1} - x_n)u_{k-1}(x_n)$$

$$u_{k-1}^*(x_{n+1}) = u_{k-1}(x_n) + (x_{n+1} - x_n)f(x_n, y(x_n), u_1(x_n), u_2(x_n), \dots, u_{k-1}(x_n))$$

$$y(x_{n+1}) = y(x_n) + (x_{n+1} - x_n)(u_1(x_n) + u_1^*(x_{n+1})) / 2$$

$$u_1(x_{n+1}) = u_1(x_n) + (x_{n+1} - x_n)(u_2(x_n) + u_2^*(x_{n+1})) / 2$$

$$u_{k-2}(x_{n+1}) = u_{k-2}(x_n) + (x_{n+1} - x_n)(u_{k-1}(x_n) + u_{k-1}^*(x_{n+1})) / 2$$

$$u_{k-1}(x_{n+1}) = u_{k-1}(x_n) + (x_{n+1} - x_n) \left[ f(x_n, y(x_n), u_1(x_n), u_2(x_n), \dots, u_{k-1}(x_n)) \right. \\ \left. + f(x_{n+1}, y(x_{n+1}), u_1(x_{n+1}), u_2(x_{n+1}), \dots, u_{k-2}(x_{n+1}), u_{k-1}^*(x_{n+1})) \right] / 2$$

解法的限制：

$$\frac{d^k y}{dx^k} = f(x, y, y', y'', \dots, y^{(k-1)})$$

- (1) 當  $f(x, y, y', y'', \dots, y^{(k-1)})$  為無窮大 (例如 singular point)  
或者  $f(x, y, y', y'', \dots, y^{(k-1)})$  雖然不是無窮大，但是值相當大  
用以上的方法會產生問題
- (2) 必需有  $k$  個在同一點的 initial conditions

## 1-4 Applications of Nonlinear Differential Equations

火箭的例子 (1-4-1)

拿鏈子的例子 (1-4-2)

D. G. Zill and Michael R. Cullen, Differential Equations-with Boundary-Value Problem (metric version), 9th edition, Cengage Learning, 2017. (Section 5-3)

# 1-4-1 火箭的例子

$$F = ma \quad F = m \frac{d^2 y(t)}{dt^2}$$

F 會隨著 y 而改變 (萬有引力定律)

$$-k \frac{mM}{y^2(t)} = m \frac{d^2 y(t)}{dt^2}$$

萬有引力

$$F_0 - k \frac{mM}{y^2} = m u \frac{du}{dy}$$

$$(F_0 - k \frac{mM}{y^2}) dy = m u du$$

M: 地球的質量

m: 火箭的質量

• 修正:

$$F_0 - k \frac{mM}{y^2(t)} = m \frac{d^2 y(t)}{dt^2}$$

推進力

without independent variable t

page 70 (2)  
 y → new indep. variable  
 $\frac{dy}{dt} = u, \frac{d^2 y}{dt^2} = u \frac{du}{dy}$

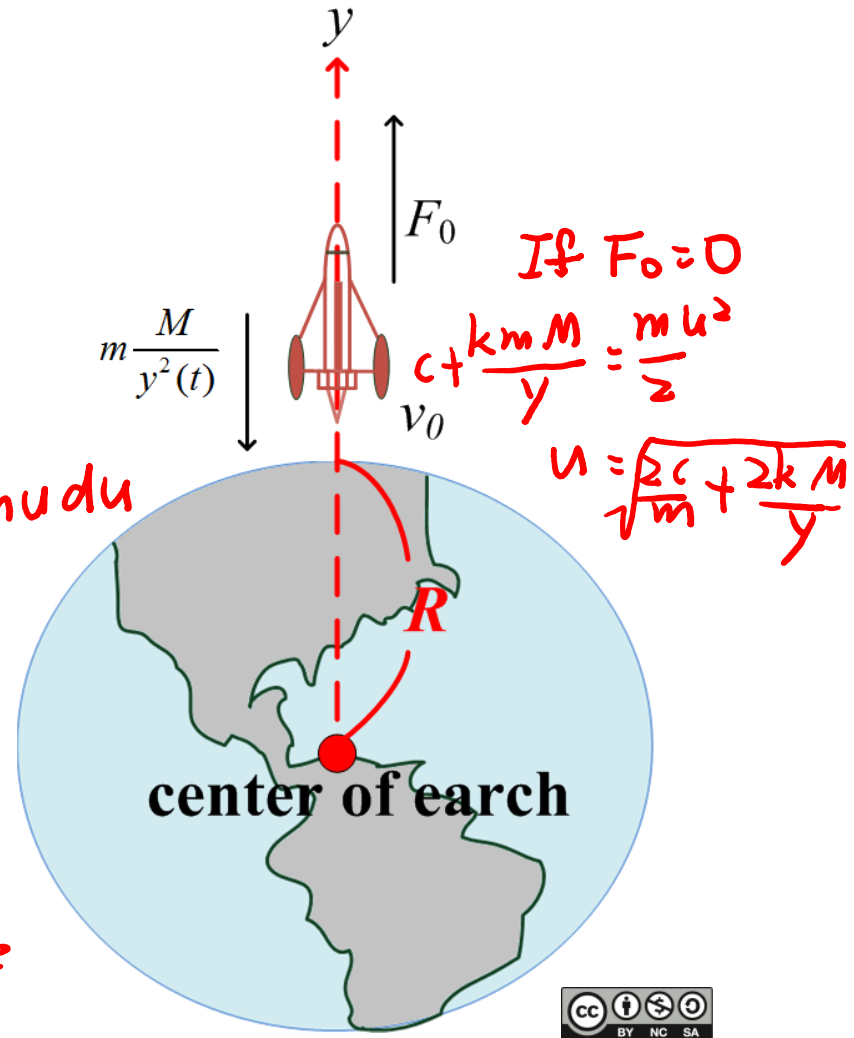

## 1-4-2 拿鏈子的例子

$$F = \frac{d}{dt}mv$$

$m$ : 質量,  $v$ : 速度,  $mv$ : 動量

$m$  會隨著  $x$  而改變 (拿鏈子的例子),

$$m = kx(t)$$

重量 (weight) =  $x(t)$

質量 (mass) =  $x(t)/9.8$

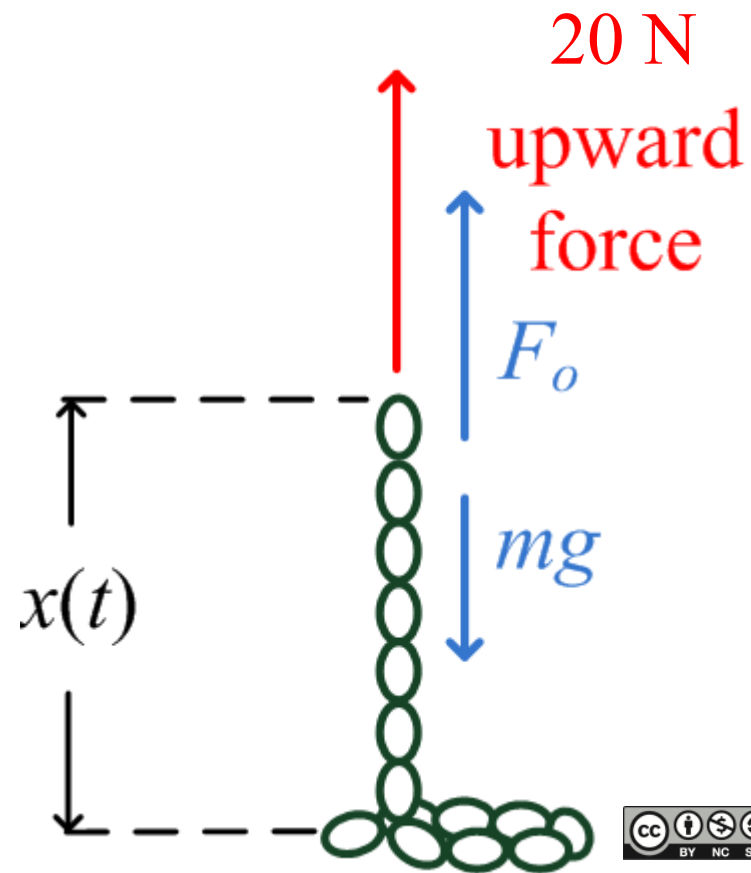

$$F_0 - mg = v \frac{d}{dt} m + m \frac{d}{dt} v, \quad (F = F_0 - mg)$$

$$F_0 - kgx(t) = \left( \frac{d}{dt} x(t) \right) \frac{d}{dt} kx(t) + kx(t) \frac{d^2}{dt^2} x(t),$$

$$kx(t) \frac{d^2}{dt^2} x(t) + k \left( \frac{d}{dt} x(t) \right)^2 + kgx(t) = F_0$$

$F_0$ : 施力,  $k$ : 每單位長的質量,  $x(t)$  高度 (如前頁)

小常識：使用公制時， $g = 9.8$  metres per  $s^2$   
使用英制時， $g = 32$  feet per  $s^2$

[Example 1] (Zill page 227)

$$x \frac{d^2 x}{dt^2} + \left( \frac{dx}{dt} \right)^2 + 9.8x = 196$$

page 70 (2)

$$u = \frac{dx}{dt}, \quad \frac{d^2 x}{dt^2} = u \frac{du}{dx}$$

$$xu \frac{du}{dx} + u^2 + 9.8x = 196$$

$$\frac{du}{dx} + \frac{u}{x} + \frac{(9.8x - 196)u^{-1}}{x} = 0$$

$$v = u^{1-n} = u^2$$

$$k = 1/9.8$$

$$g = 9.8$$

$$F_0 = 20$$

Bernoulli,  $n = -1$   
page 31